

# Distributed Transactions in Spanner 2



جامعة الملك عبد الله  
للعلوم والتقنية  
King Abdullah University of  
Science and Technology

---

CS 240: Computing Systems and Concurrency  
Lecture 20

Marco Canini

# Recap: Spanner is Strictly Serializable

---

- Efficient read-only transactions in strictly serializable systems
  - Strict serializability is desirable but costly!
  - Reads are prevalent! (340x more than write txns)
  - Efficient ro-txns → good overall performance

# Recap: TrueTime

---

- Timestamping writes must enforce the invariant
  - If T2 starts after T1 commits (finishes), then T2 must have a larger timestamp
- TrueTime: partially-synchronized clock abstraction
  - Bounded clock skew (uncertainty)
  - $TT.now() \rightarrow [earliest, latest]; earliest \leq T_{abs} \leq latest$
  - Uncertainty ( $\epsilon$ ) is kept short
- TrueTime enforces the invariant by
  - Use **at least**  $TT.now().latest$  for timestamps
  - **Commit wait**

# Enforcing the Invariant with TT

If T2 starts after T1 commits (finishes), then T2 must have a larger timestamp

Let T1 write  $S_B$  and T2 write  $S_A$

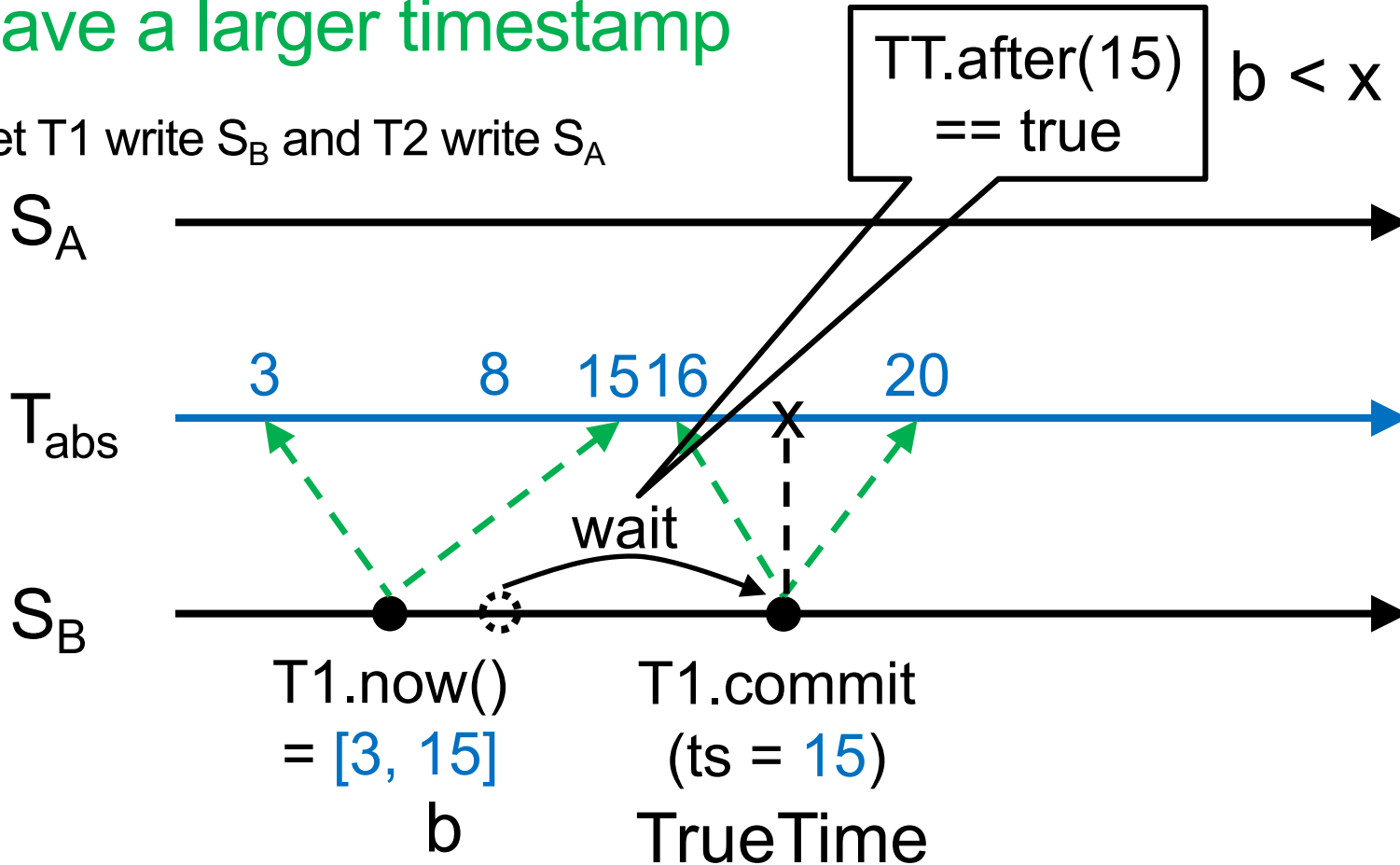

# Enforcing the Invariant with TT

If T2 starts after T1 commits (finishes), then T2 must have a larger timestamp

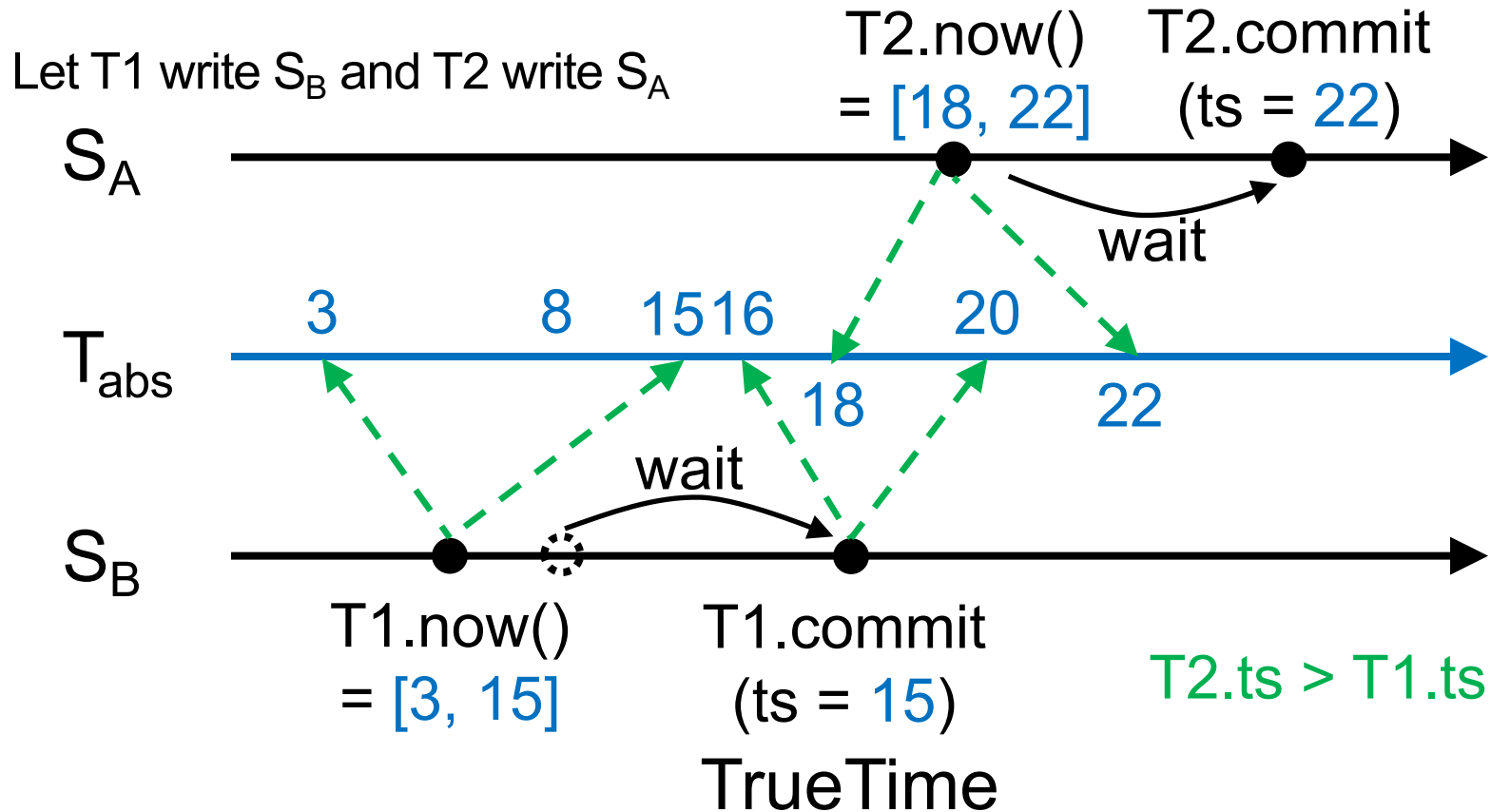

# Strictly Serializable Multi-Shard Transactions

---

- How are clocks made “nearly perfect”?
  - TrueTime
- How does Spanner leverage these clocks?
  - How are writes done and tagged?
  - How read-only transactions are made efficient?

# Scale-out vs. fault tolerance

---

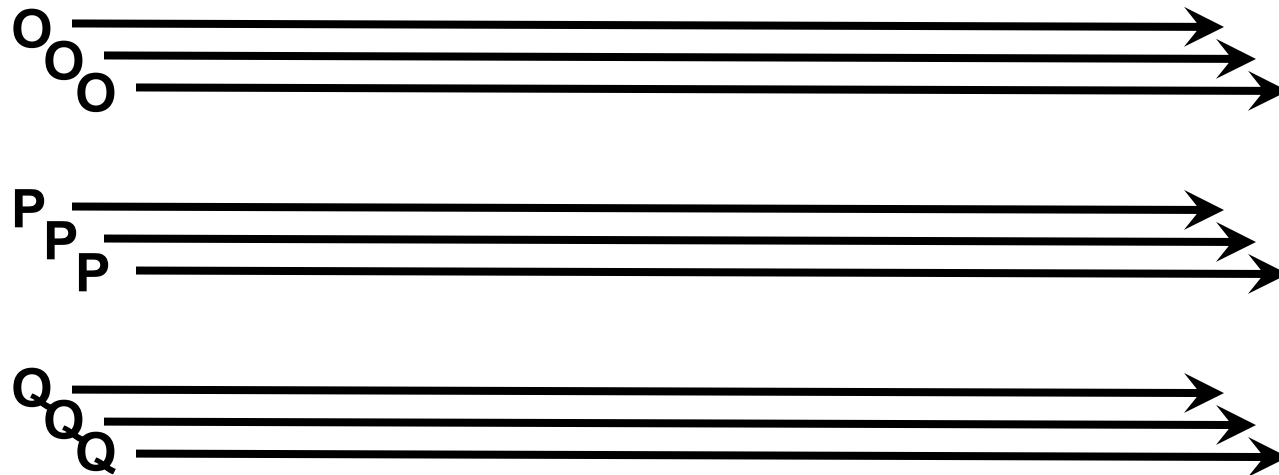

## Spanner mechanisms

- 2PL for concurrency control of read-write transactions
- 2PC for distributed transactions over tables
- (Multi)Paxos for replicating every tablet

# This Lecture

---

- How write transactions are done
  - 2PL + 2PC (sometimes 2PL for short)
  - How they are timestamped
- How read-only transactions are done
  - How read timestamps are chosen
  - How reads are executed



# Read-Write Transactions (2PL)

---

- Three phases

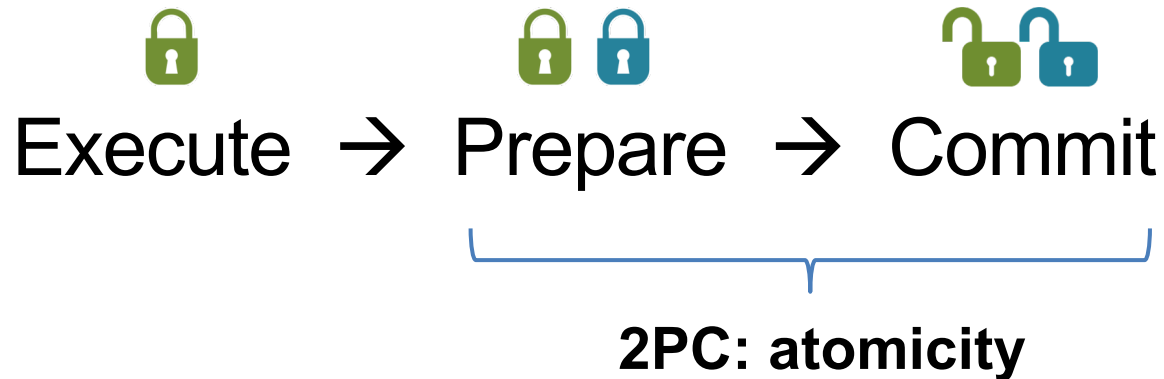

# Client-driven transactions (multi-shard)

---

Client: 2PL w/ 2PC

1. Issues reads to leader of each shard group, which acquires read locks and returns most recent data
2. Locally performs writes
3. Chooses coordinator from set of leaders, initiates commit
4. Sends commit message to each leader, include identity of coordinator and buffered writes
5. Waits for commit from coordinator

# Read-Write Transactions (2PL)

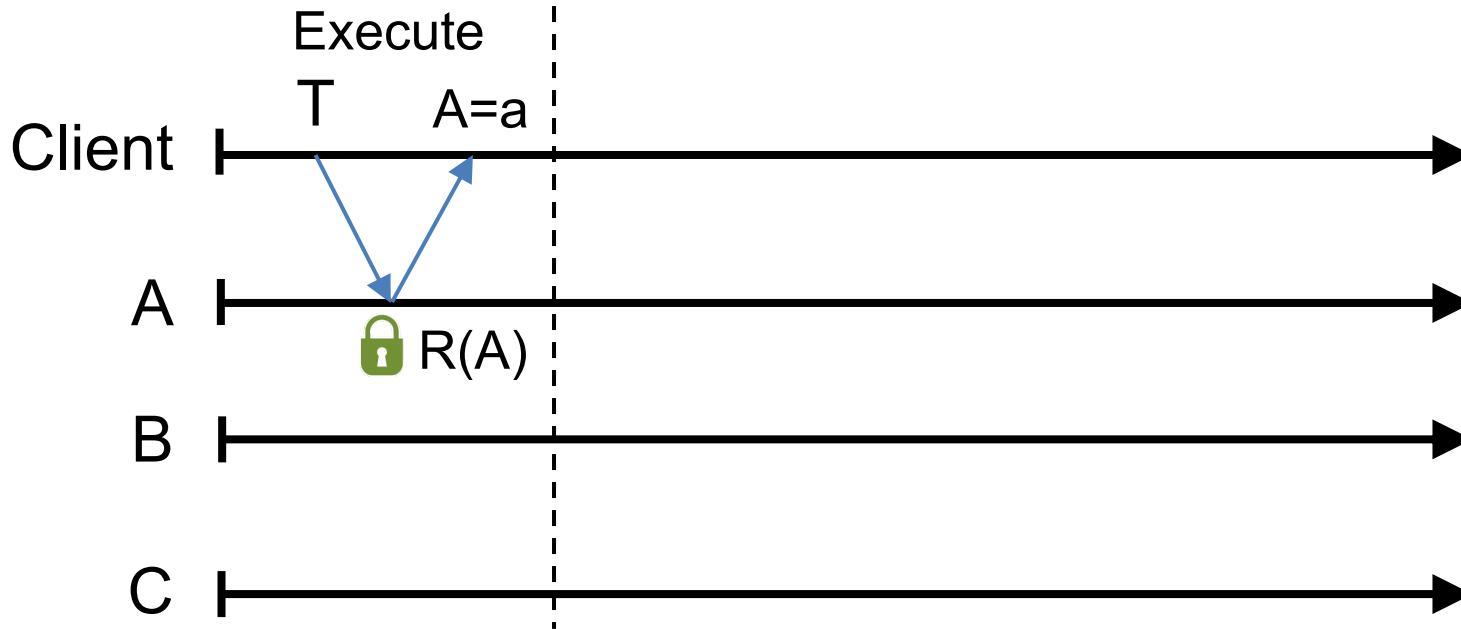

Txn T = {R(A=?), W(A=?+1), W(B=?+1), W(C=?+1)}

## Execute:

- Does reads: grab read locks and return the most recent data, e.g., R(A=a)
- Client computes and buffers writes locally, e.g., A = a+1, B = a+1, C = a+1

# Read-Write Transactions (2PL)

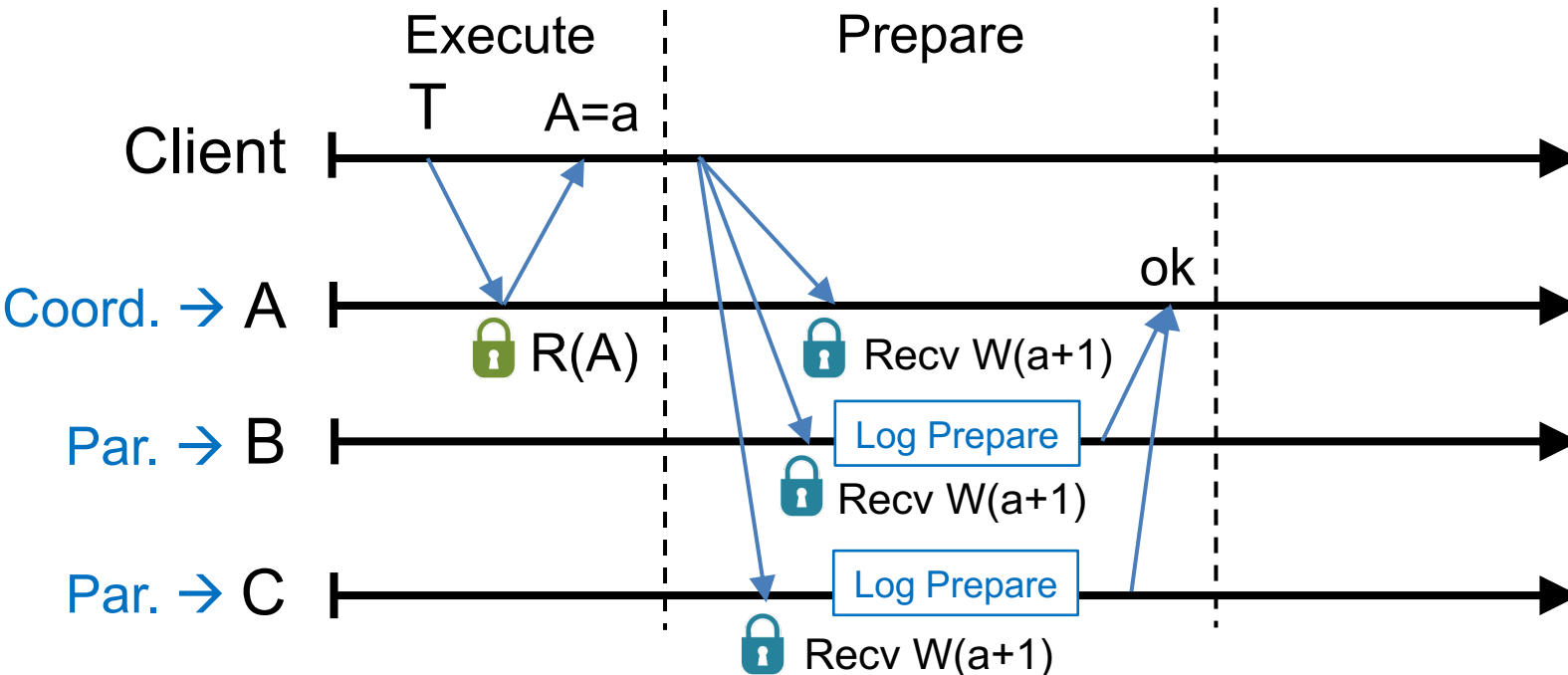

## Prepare:

- Choose a coordinator, e.g., A, others are participants
- Send buffered writes and the identity of the coordinator; grab write locks
- Each participant prepares  $T$  by logging a prepare record via Paxos with its replicas. Coord skips prepare (Paxos Logging)
- Participants send OK to the coord if lock grabbed and after Paxos logging is done

# Read-Write Transactions (2PL)

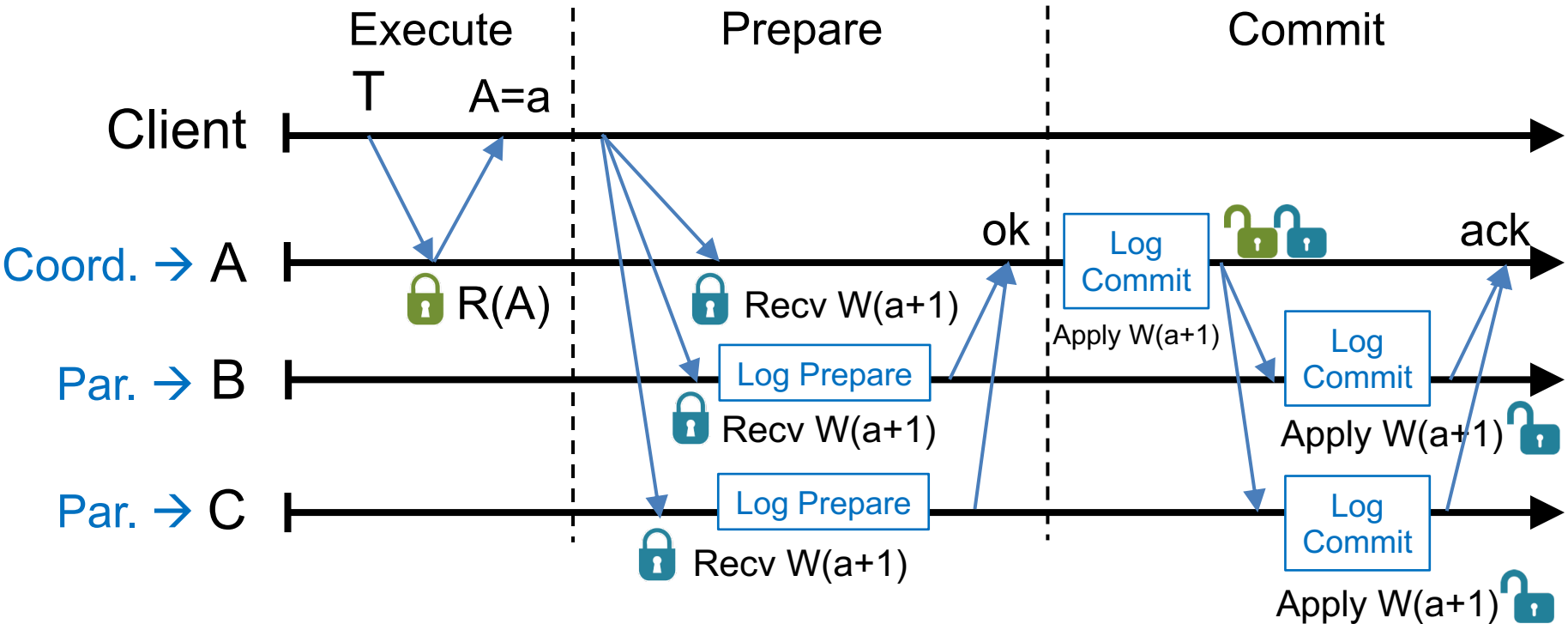

## Commit:

- After hearing from all participants, coord commits  $T$  if all OK; otherwise, abort  $T$
- Coord logs a commit/abort record via Paxos, applies writes if commit, release all locks
- Coord sends commit/abort messages to participants
- Participants log commit/abort via Paxos, apply writes if commit, release locks
- Coord sends result to client either after its “log commit” or after ack

# Timestamping Read-Write Transactions

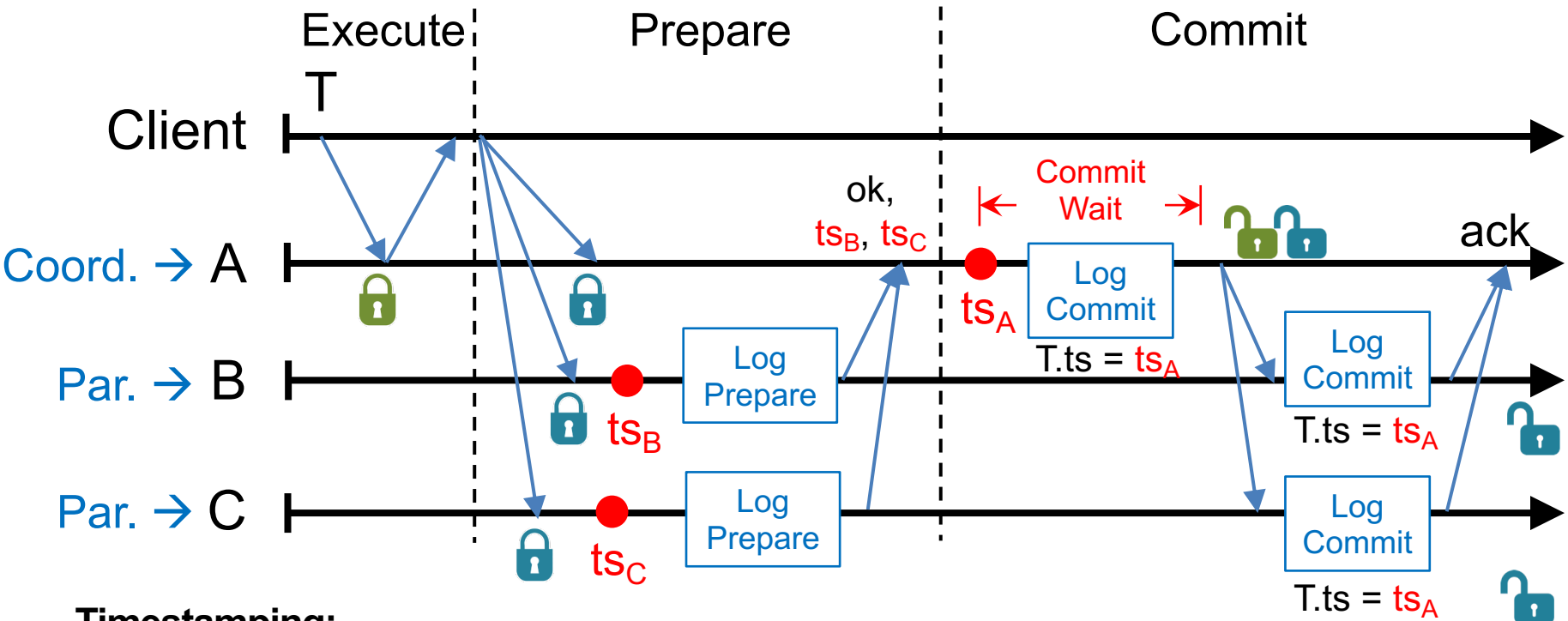

## Timestamping:

- Participant: choose a timestamp, e.g.,  $ts_B$  and  $ts_C$ , larger than any writes it has applied
- Coordinator: choose a timestamp, e.g.,  $ts_A$ , larger than
  - Any writes it has applied
  - Any timestamps proposed by the participants, e.g.,  $ts_B$  and  $ts_C$
  - Its current `TT.now().latest`
- Coord **commit-waits**: `TT.after( $ts_A$ ) == true`. Commit-wait overlaps with Paxos logging
- $ts_A$  is  $T$ 's commit timestamp

# Ideas Behind Read-Only Txns

---

- Tag writes with physical timestamps upon commit
  - Write txns are strictly serializable, e.g., 2PL
  
- Read-only txns return the writes, whose commit timestamps precede the reads' current time
  - Ro-txns are one-round, lock-free, and never abort

# Read-Only Transactions (shards part)

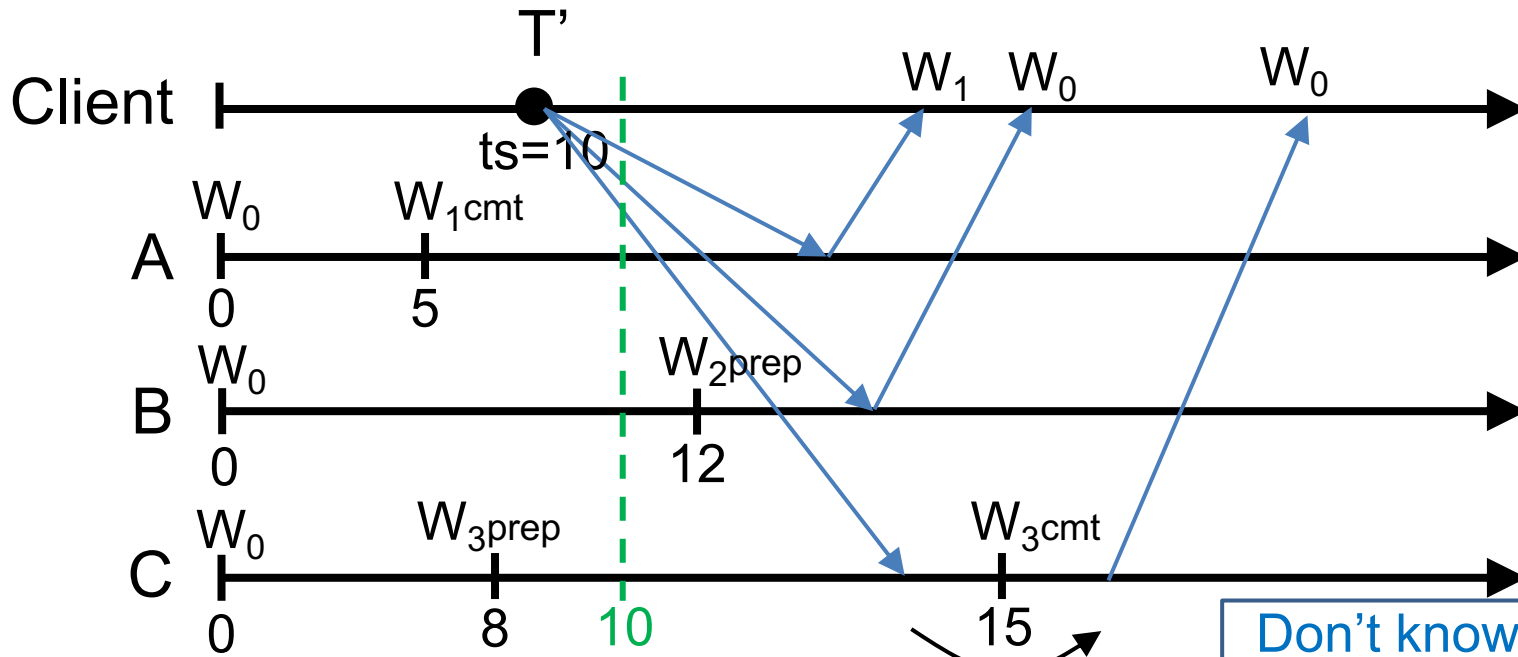

Txn  $T' = R(A=?, B=?, C=?)$

- Client chooses a read timestamp  $ts = TT.now().latest$
- If no prepared write, return the preceding write, e.g., on A
- If write prepared with  $ts' > ts$ , no need to wait, proceed with read, e.g., on B
- If write prepared with  $ts' < ts$ , wait until write commits, e.g., on C



# Read-Only Transactions (Paxos part)

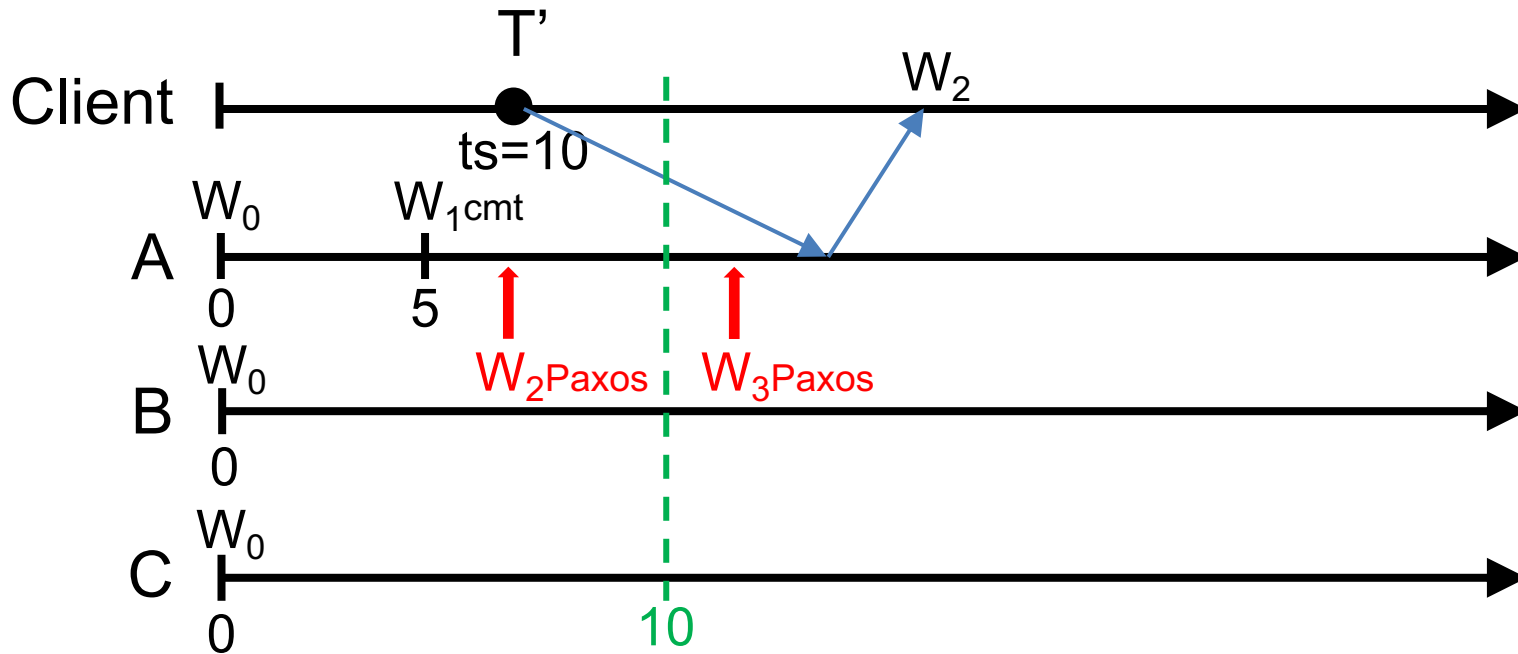

- Paxos writes are monotonic, e.g., writes with smaller timestamp must be applied earlier,  $W_2$  is applied before  $W_3$
- $T'$  needs to wait until there exists a Paxos write with  $ts > 10$ , e.g.,  $W_3$ , so all writes before 10 are finalized
- Put it together: a shard can process a read at  $ts$  if  $ts \leq t_{safe}$
- $t_{safe} = \min(t_{safe}^{Paxos}, t_{safe}^{TM})$ : before  $t_{safe}$ , all system states (writes) have finalized

# A Puzzle to Help With Understanding

- What if no replication, only shards
  - Not in the paper, not realistic

Txn  $T = \{W_A, W_C\}$ ,  $T' = R(A, C)$

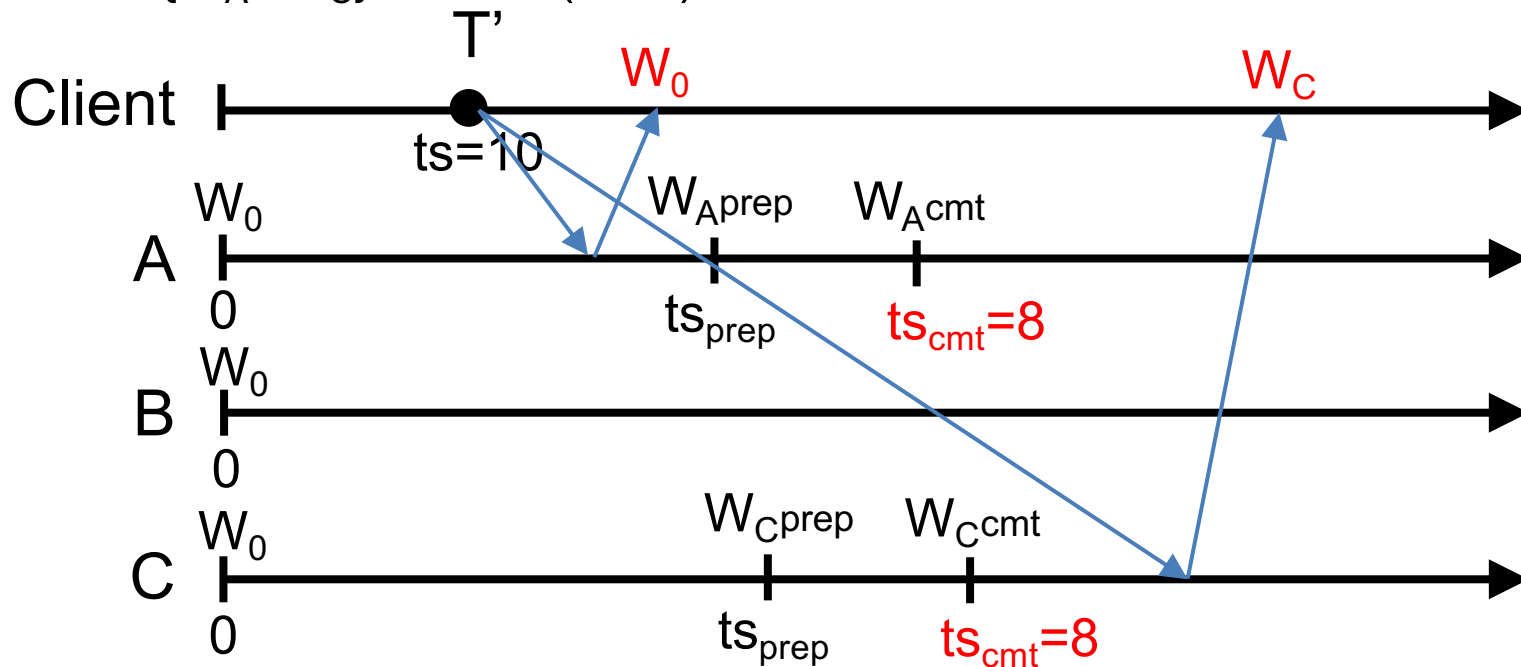

$T'$  sees partial effect of  $T$ , e.g., sees  $W_C$  but not  $W_A$ , and violates atomicity

# A Puzzle to Help With Understanding

- Solution: uncertainty-wait

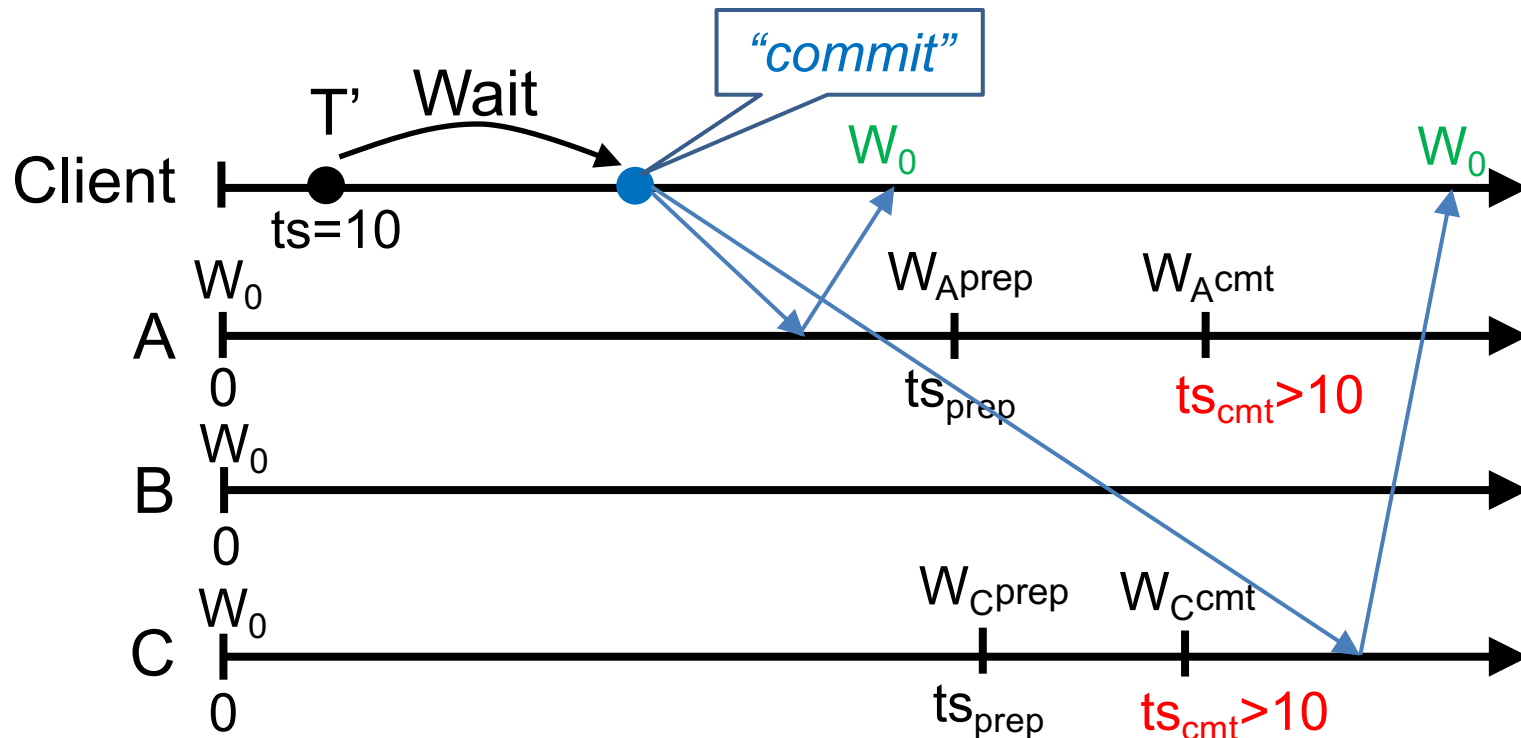

Uncertainty-wait ensures that  $ts_{cmt}$  must  $>$  readTS because

- $W_1$  starts after  $T'$  "commits," and
- $T'$  waits out uncertainty before "commit", e.g.,  $TT.after(10) == true$

# Serializable Snapshot Reads

---

- Client specifies a read timestamp way in the past
  - E.g., one hour ago
- Read shards at the stale timestamp
- Serializable
  - Old timestamp cannot ensure real-time order
- Better performance
  - No waiting in any cases
  - E.g., non-blocking, not just lock-free

# Takeaway

---

- Strictly serializable (externally consistent)
  - Make it easy for developers to build apps!
- Reads dominant, make them efficient
  - One-round, lock-free
- TrueTime exposes clock uncertainty
  - Commit wait and at least `TT.now.latest()` for timestamps ensure real-time ordering
- Globally-distributed database
  - 2PL w/ 2PC over Paxos!